

5 SERIES - 1/6 HP

APPLICATIONS

The 5-Series is one of the most compact utility pumps on the market. Ideal for light commercial and multi-purpose residential applications where water removal, transfer, or circulation is required.

FEATURES

- Corrosion- and rust-resistant, epoxy-coated cast aluminum pump housing gives strength and high heat dissipation for both consumer and professional use
- Rated for continuous duty which allows for a wide range of applications and uses
- Compact design with manual version weighing in just under seven pounds makes this pump truly portable
- 1/6 hp energy efficient and oil free PSC motor is environmentally friendly and delivers 1500 gph maximum capacity
- FKM triple-lip seal
- Upper and lower ball bearings for long life
- 1" FNPT (25.4 mm) discharge (includes garden hose adapter for quick plug and play)
- Removable inlet screen allows for easy cleaning without tools
- In manual operation, pumps down to 1/8" (3.2 mm) with screen, and down to 1/16" (1.6 mm) without screen to reduce overall water removal clean up time and effort
- Multiple switch options for automatic operation gives application flexibility
- Multiple power cord lengths available
- 120 °F (49 °C) maximum liquid temperature rating
- cULus on items 505723, 505712, 505714, 505715, 505717



5-MSP

5-ASP



SERIES SPECIFICATIONS

Volts	Hz	Amps FLA	Watts	Performance (GPH / Liters per Minute @ Height)					Shut-Off	PSI
				1 ft / 0.3 m	3 ft / 0.9 m	5 ft / 1.5 m	10 ft / 3 m	20 ft / 6.1 m		
115	60	2.0	220	1500	1464	1395	1191	528	26 ft / 7.9 m	11.43
				5678	5542	5281	4508	1999		
230	60	1.0	220	1500	1464	1395	1191	528	26 ft / 7.9 m	11.43
				5678	5542	5281	4508	1999		

Item No.	Model	HP	Volts	Switch Type/ Operation	On Level	Off Level	Cord	Weight
505715	5-ASP	1/6	115	Piggyback Diaphragm (Standard Version)	6" - 9" 15.2 cm - 22.9 cm	1" - 4" 2.5 cm - 10.2 cm	10' 3 m	7.5 lbs 3.4 kg
505717	5-ASP-LL	1/6	115	Piggyback Diaphragm (Low Level Version)	2" - 3" 5.1 cm - 7.6 cm	1/2" - 1-1/2" 1.3 cm - 3.8 cm	18' 5.5 m	8.0 lbs 3.6 kg
505711	5-MSP Hydroponics	1/6	115	Manual	-	-	10' 3 m	7.0 lbs 3.2 kg
505718	5-ASP-LL Hydroponics	1/6	115	Piggyback Diaphragm (Low Level Version)	2" - 3" 5.1 cm - 7.6 cm	1/2" - 1-1/2" 1.3 cm - 3.8 cm	18' 5.5 m	8.0 lbs 3.6 kg
505723	5-MSP	1/6	115	Manual	-	-	10' 3 m	7.0 lbs 3.2 kg
505712	5-MSP	1/6	115	Manual	-	-	25' 7.6 m	7.4 lbs 3.4 kg
505714	5-MSP	1/6	230	Manual	-	-	12' 3.7 m	7.0 lbs 3.2 kg
505721	5-MSP	1/6	127	Manual	-	-	18' 5.5 m	7.2 lbs 3.3 kg

5 SERIES - 1/6 HP

ENGINEERING DATA

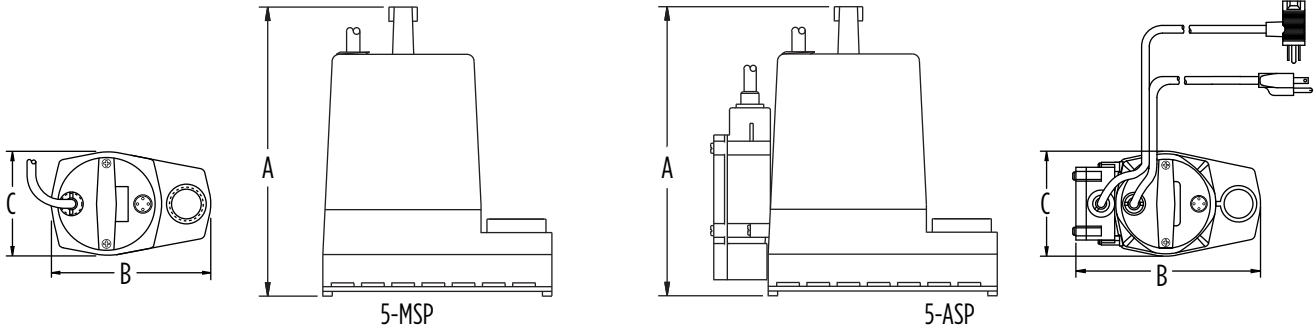

Model	A	B	C
5-MSP	8.07" 20.50 cm	6.10" 15.50 cm	4.29" 10.90 cm
5-ASP	8.07" 20.50 cm	7.75" 19.69 cm	4.29" 10.90 cm

PERFORMANCE DATA

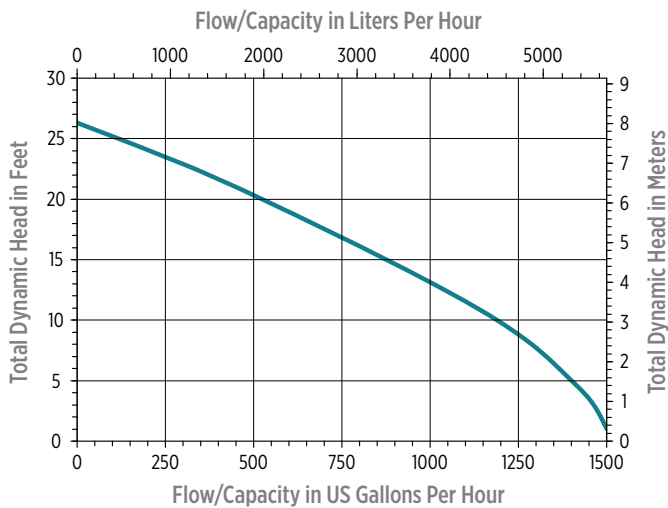

CONSTRUCTION

Motor Housing	Epoxy-coated cast aluminum
Impeller Material	Nylon
Impeller Type	Semi-open
Volute	Nylon
Motor Shaft	Stainless steel
Shaft Seal	Fluoroelastomer (FKM)
Fasteners	Stainless steel
Bearings	Upper and lower ball bearing
Power Cord	SJTW
RPM	3450
Motor Type	PSC