

205FLF Boiler Drain • Spec Sheet



FEATURES & BENEFITS

- Lead Free Brass*
- 125 WOG
- Boiler Drain - Full Flow
- Angle Spout
- Stuffing Box
- ISO-9002
- NSF/ ANSI 61, ASME & CSA Approved

DIMENSIONS

Part	Size	L	H	D
205F03LF	1/2" MIP X 3/4" Hose	1.46	3.59	2.08
205F04LF	3/4" MIP X 3/4" Hose	1.46	3.59	2.08
205FF3LF	1/2" FIP X 3/4" Hose	1.46	3.35	2.08
205FF4LF	3/4" FIP X 3/4" Hose	1.46	3.35	2.08

205F

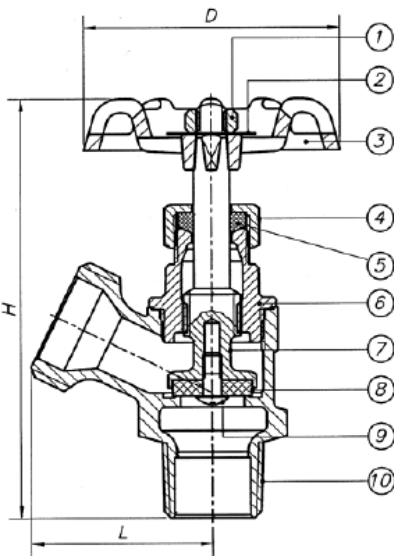

205FF

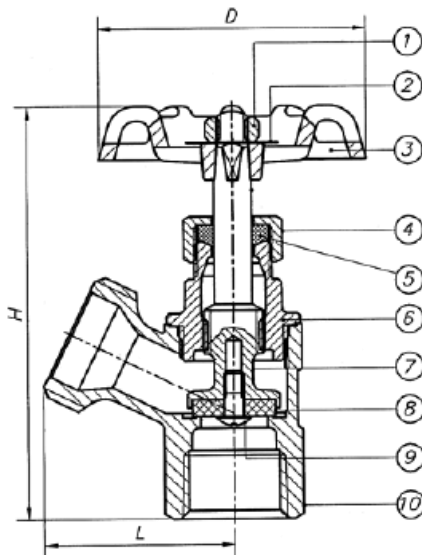

MATERIAL SPECIFICATIONS

No.	Parts	Material
1	Wheel Nut	Hot Rolled SAE 1010R
2	Name Plate	Aluminum A1100
3	Handle Wheel	Cast Iron
4	Packing Nut	Brass C89550
5	Gland Packing	PTFE
6	Bonnet	Brass C89550
7	Stem	Brass C89550
8	Seat Packing	BUNA
9	Seat Screw	Brass B19 C26000
10	Body	Brass C89550

* These product complies with 0.25% weighted average lead content on wetted surfaces in accordance with Safe Water Drinking Act (SDWA) / Federal Public Law No. 111-380.



Global sourcing. National compliance. Local service.

CALIFORNIA 5593 Fresca Dr., La Palma CA 90623 • Toll Free: 866-532-8306 • Fax: 866-532-8307
TEXAS 1150 Silber Rd., Houston TX 77055 • Toll Free: 800-935-5456 • Fax: 713-680-2999
NEW YORK PO Box 27, Rt. 22, Brewster NY 10509 • Toll Free: 800-431-2082 • Fax: 845-278-9056
 WEB: www.matco-norca.com EMAIL: mail@matco-norca.com