

1-YS SERIES - 1/150 HP

APPLICATIONS

This parts washer pump is for use with Stoddard solvent and deodorized kerosene submerged parts washer applications only. These refined petroleum distillates from the parts washer pump are free from the tendency to heat spontaneously and have a closed cup flash point no lower than 100 °F (37.8 °C).

FEATURES

- Oil-filled aluminum housing
- Nylon volute & impeller
- Conduit fitting for mounting
- Submerged use only in parts washers
- Fluoroelastomer (FKM) shaft seal
- For use with UL (PIQU) solvents
- 205 GPH @ 1'
- 6' cord, no plug
- Thermally protected



1-YS



SERIES SPECIFICATIONS

Model No.	Item No.	Discharge Size	Listing	HP	Volts	Hertz	Amps	Watts	Performance (GPM@Head)			Shutoff		Cord Length (ft.)	Weight (lbs.)
									1'	3'	5'	Ft.	P.S.I.		
1	501020	1/4" MNPT	UR/C-CSA	1/150	115	60	1.1	70	205	168	120	7.4	3.2	6	3.5
1-YS	501036	1/4" MNPT		1/150	230	50/60	0.6	70	205	168	120	7.4	3.2	6	3.5

SPECIALTY PUMPS

1-YS SERIES - 1/150 HP

ENGINEERING DATA

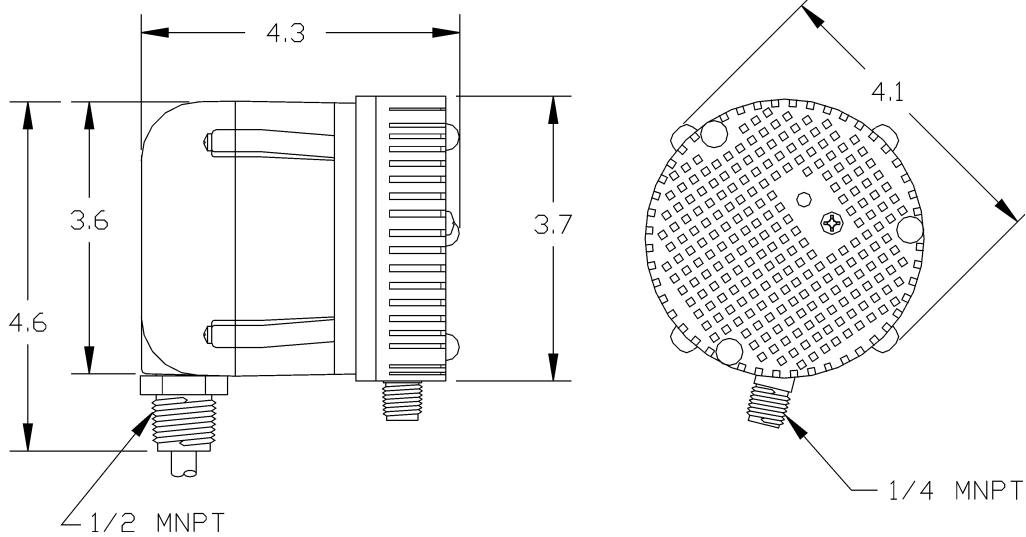

PERFORMANCE DATA

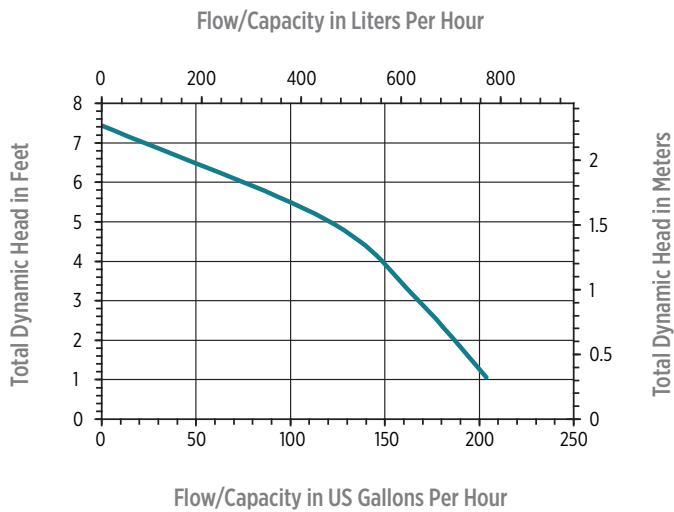

REPLACEMENT PARTS

Volute	101351
Impeller	101433
Screen	101351

